

The code can be changed with the unit fitted on/off the door/gate. The unit is non sequential, therefore if the code is set to 1234, the keypad will open if entered 4321, 3214 etc.. There are over 4000 different code combinations available. Please note: whilst the keypad lever handle will turn, the spindle follower on the back of the keypad will not rotate until the correct code has been entered this is designed to prevent misuse/abuse.

**The code should be changed with the door/gate in the open position. If the unit has keypad both sides, the code will need to be changed on both keypads.**

**To change the code you will need to know what the keypad is currently set to and have the code change key.**

1. Enter existing code
2. Using the code change key insert into the hole in the \* button.  
**Fully press and hold the code change key (until step 5) as per Fig.1 below.**

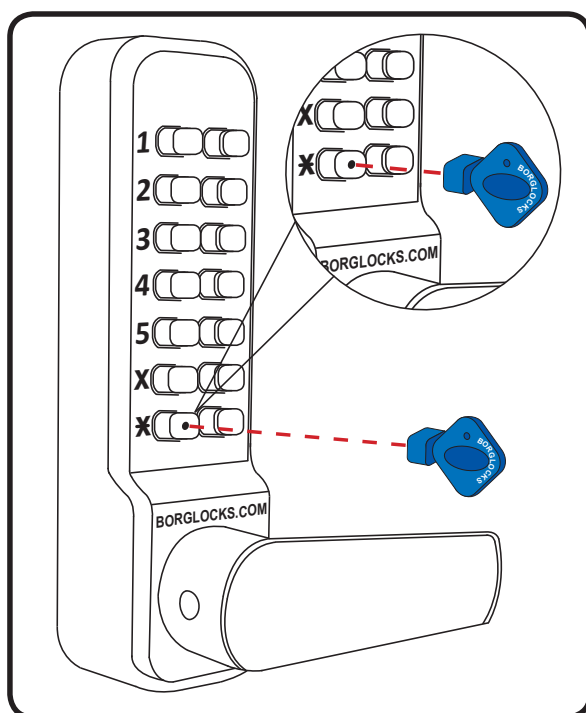

**Fig.1**

3. Press 'C' button to clear the existing code.
4. Press the digits that are to be in the new code. Once the new code has been entered, press all the digits in the code once again to ensure that all the digits in the code are set.
5. Release the code change key from hole in the \* button.
6. Press 'C' button or rotate the lever handle to set the new code.
7. The new code is now set and ready for use.
8. Check that the code is working 5 times and that it is withdrawing the latch/deadbolt before closing the door/gate.

Please note: If a new code has been set and it does not work, the 'C' button has not been pressed when clearing the old code and before inputting the new code; therefore the code will be a combination of the new and old code i.e. if the old code was 1234 and the new code is 6789 the code actually set if 1234-6789. Input both the old and new code and follow the code change from step 2.

If the code has been changed and the keypad lever handle is free turning and retracting the latch/deadbolt, the new code has not been set and no code is currently set - follow the code change from step 2.

In the event of a code that has been lost or forgotten, the unit will need to be removed from the door/gate. If the unit has keypads on both sides, the fixing screws are located on the top and bottom of the inside keypad.

1. With the unit removed from the door turn the keypad over and you will see that there is 12 portholes which correlate with the buttons of the keypad, through these holes you will see blue and red lines.
2. Press the 'C' button to reset any buttons which may have been pressed.
3. To identify the code the keypad has been set to, you are looking for the red lines which are closest to the centre of the portholes.
4. As per **Fig.2** below, you will see that the red lines on digits 2, 4, 6 and 8 are closest to the centre of the porthole and is the code. All the other holes will show a blue line - these are not in the code. Once all the coded buttons have been pressed all of the 12 portholes will have a blue lines in the centre.
5. There is no sequence to the code so as long as all the buttons in the code are pressed the knob will rotate.
6. Once you have identified the code of the unit, make a note of the code before refitting the unit to the door. The code can be changed with the unit on/off the door.

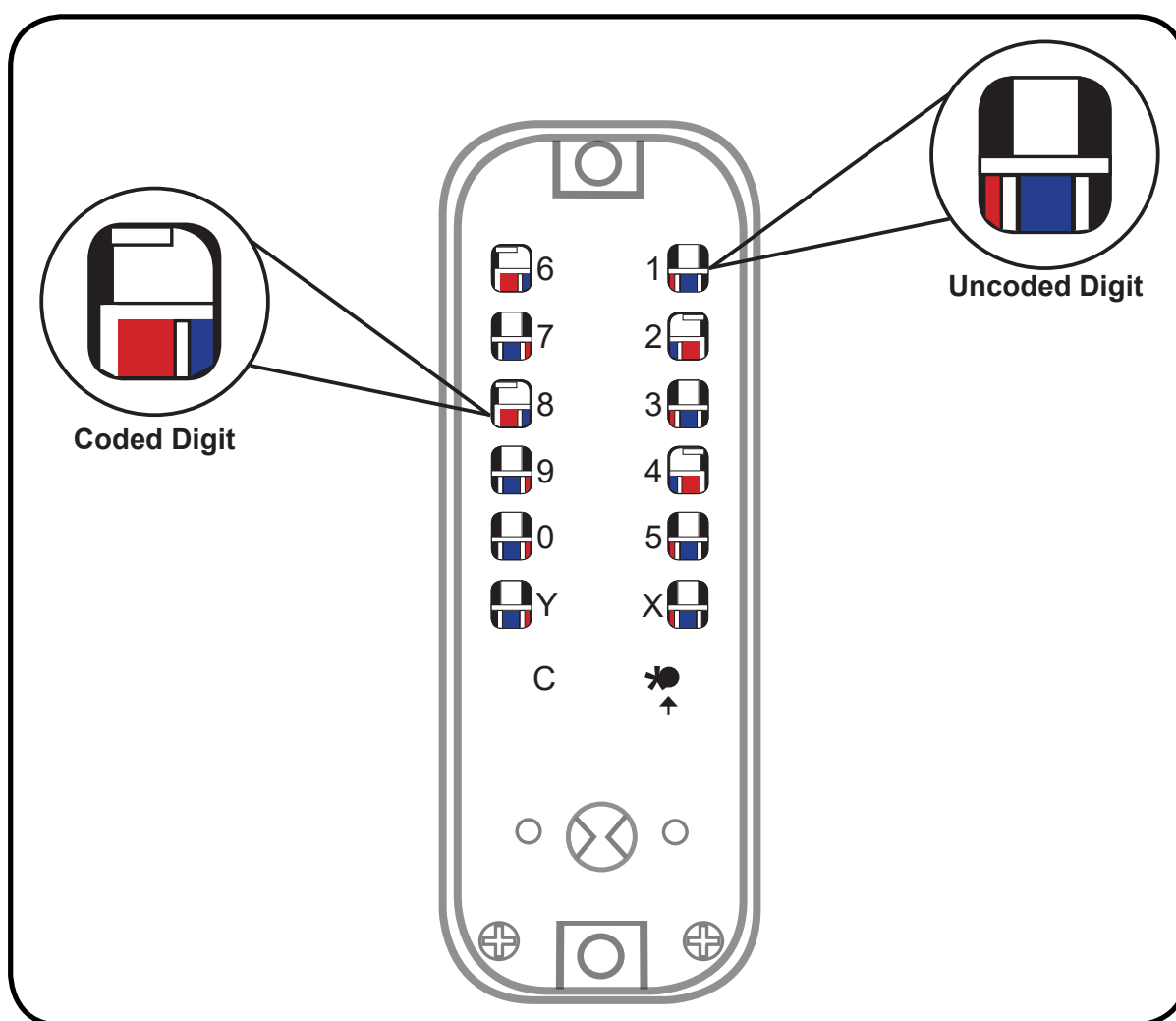

**Fig.2**