

## Product Specifications

<b>Material:</b>	ABS
<b>Technology:</b>	Radio & Bluetooth
<b>Type:</b>	Superheterodyne
<b>Operating mode:</b>	Pulse, Latch, Timed
<b>Frequency:</b>	433.92MHz
<b>Modulation:</b>	AM/ASK
<b>Encoding:</b>	KeeLoq® hopping code
<b>Memory:</b>	Up to 250 transmitters Up to 100 smartphone user codes
<b>Release time:</b>	1sec - 23h:59m:59s
<b>Code combinations:</b>	2 <sup>64</sup>
<b>Relays:</b>	1
<b>Contacts:</b>	C/NO/NC
<b>Weight:</b>	0.03 kg

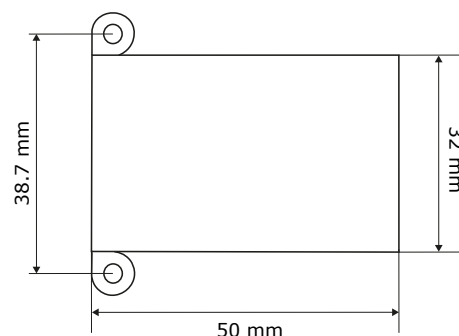

## Electrical Specifications

<b>Power supply:</b>	12-24V AC/DC (autodetect)
<b>Max power on output:</b>	1A @ 24V
<b>Consumption:</b>	78mA @ 12V AC (500mA @ power up)

## Accessories



### CMC10

10 mobile credentials licence card for CUBE X

